

GEYSER 16 L



Electric steam generators with 16 litres boiler and modular heating elements. Available in 12 kW or 15 kW size.

Product codes: 1612, 1615

DESCRIZIONE:

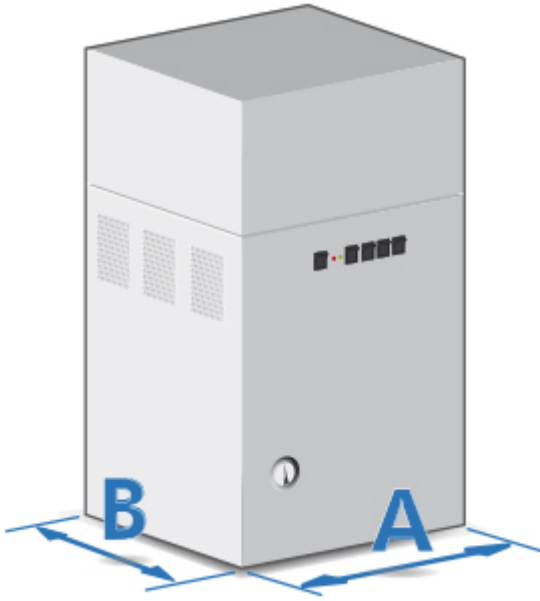

Compact

- Compact design, small footprint.
- With two free sides for easy location.
- Easy installation.



Designed for energy saving

- Modular heating elements: turn on only what you need. The optional Geysler-TRON device allows further savings.
- High performance insulation for higher efficiency.
- Optional condensate recovery tank.
- Optional heat recovery “economizer” device.
- Except in case of extremely hard water, no water softening is required.

**Safe and durable**

- No exposed hot or electrical parts.
- Alarm light on front panel.
- Double protection against overheating and overpressure.
- High quality materials: stainless steel water tank, all-metal piping.
- Insulation cover of the pressure vessel made of fireproof material.

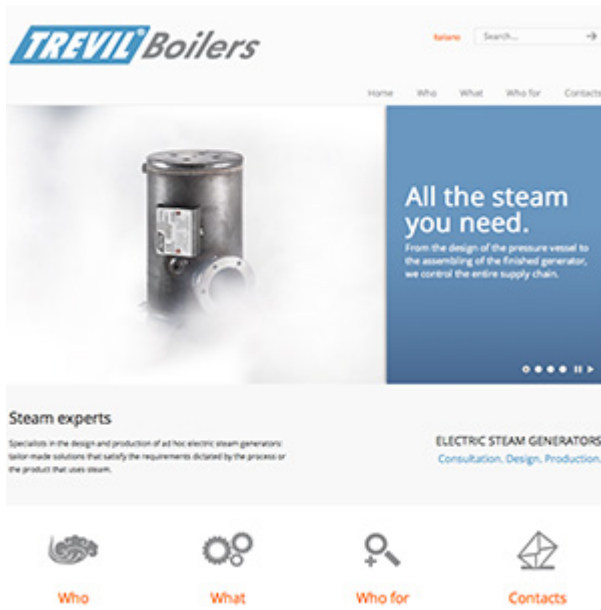

Customizable

Our TREVIL Boilers business unit offers consulting services and custom design for your special applications. Visit www.trevilboilers.com to learn more about what TREVIL Boilers can do for you.

|

MAIN FEATURES



Modular heating elements

The total power of the generator is split into smaller heating elements that may be individually controlled. The number of heating elements in function can be changed according to steam consumption. The (optional) Geysers-TRON system performs this action automatically.



Incoloy elements

We use premium Incoloy elements which feature superior resistance to heat and stress corrosion. Incoloy elements also reduce the need for boiler cleaning, as they naturally remain cleaner from limescale compared to other materials.

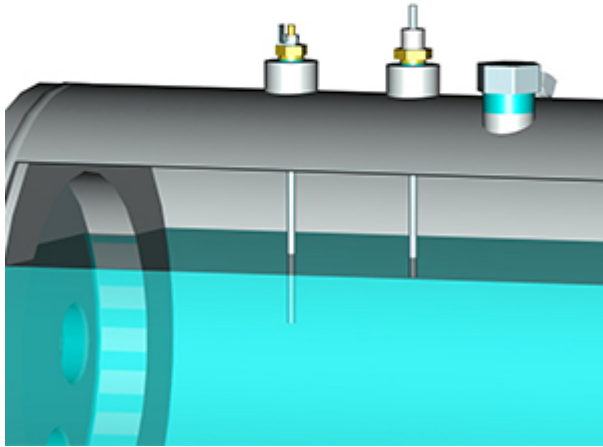

Electronic level control

The water level in the boiler is electronically controlled and refilled by an electric pump. Check valves prevent water backflow into the supply line and boiler flooding during hours of inactivity.

The level control circuit has been designed so as to prevent phenomena of galvanic corrosion.

The level control circuit has built-in protections against generator malfunction, for example dry running and excess pressure.

There is no floating ball and therefore no mechanical parts that may fail.

OPTIONS

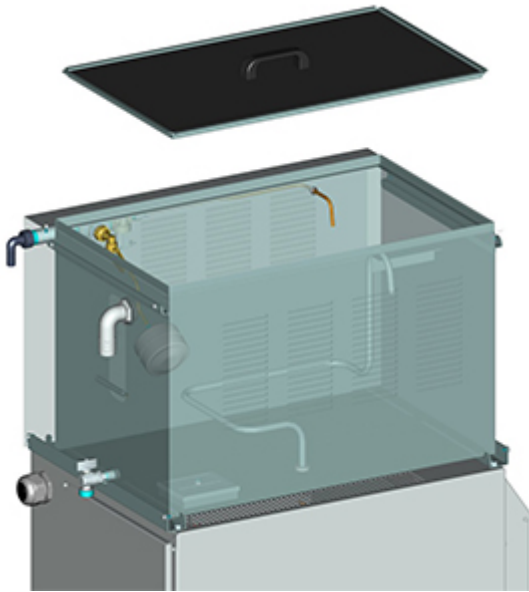

Condensate recovery tank

Each boiler can be equipped with a stainless steel water tank for condensate recovery. The temperature in the water tank is controlled by thermostat. There is no steam plume.

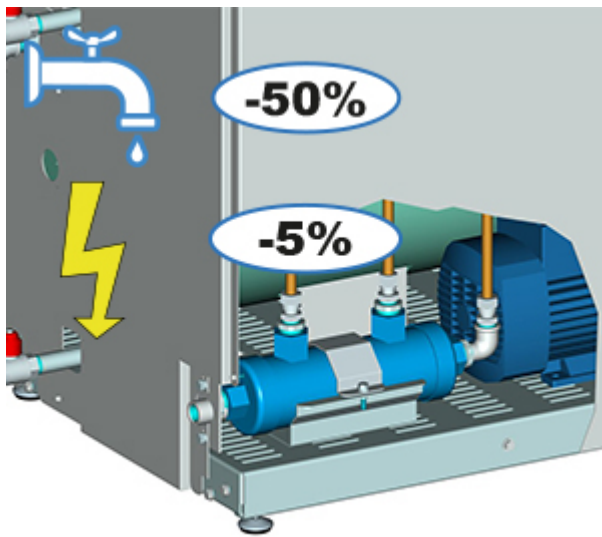

Economizer

The economiser allows 50% saving on water consumption and 5% on energy consumption.

The condensate recovery tank, by itself, allows saving water and energy. Higher savings can be reached implementing our economizer, that is a heat exchanger which pre-heats the water entering the boiler exploiting the latent heat of condensate entering the tank.

The economizer is particularly recommended in systems that produce much condensate.



40 litres boiler draining tank

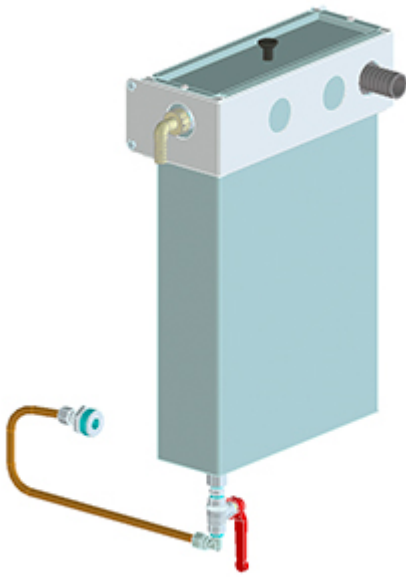

15 L tank for water feed, without condensate recovery

TECHNICAL SPECIFICATIONS

	1612	1615
Description	12 kW steam generators for central steam plants	15 kW steam generators for central steam plants
Electrical requirements	400V 3N 50Hz 400V 3 50Hz 230V 3 50Hz 220V 3 60Hz	400V 3N 50Hz 400V 3 50Hz 230V 3 50Hz 220V 3 60Hz
Total power	12,6 kW	15,6 kW
Pump power	0,6 kW 0,8 HP	0,6 kW 0,8 HP
Boiler resistance	12 kW	15 kW
Boiler volume	16 l	16 l
Steam production	16,8 kg/h 37 lbs/h	21 kg/h 46 lbs/h

	1612	1615
Steam pressure	5 bar 72 PSI	5 bar 72 PSI
Footprint	460 x 580 mm 18" x 23"	460 x 580 mm 18" x 23"
Dimensions	460 x 660 x 710 mm 18" x 26" x 28"	460 x 660 x 710 mm 18" x 26" x 28"
Net weight	68 kg 150 lbs	68 kg 150 lbs